

# Super HEAVY-DUTY blower

Model :  
- 4.5A  
- 5A  
- 5.6A

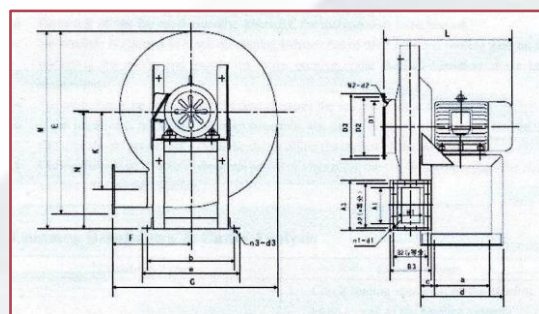

Series 9-19



Model	Inlet Diameter				Outlet Diameter								Fan Diameter								Installation Base Diameter					
	D1	D2	D3	n2-d2	A1	A2	A3	B1	B2	B3	X	Y	n1-d2	E	F	G	K	M	N	L	a	b	c	d	e	n3-d3
4.5A	φ200	φ230	φ254	4-φ7	144	176	198	104	135	160	4	3	14-φ7	749	295	657	322	778	450	495	200	390	50	300	440	4-φ15
5A	φ224	φ260	φ285	4-φ7	160	192	214	115	150	171	4	3	14-φ7	829	328	730	358	864	500	580	340	450	50	440	495	4-φ15
5.6A	φ250	φ285	φ312	8-φ10	179	212	233	129	162	185	4	3	14-φ7	925	367	817	401	958	550	690	350	480	50	450	525	4-φ15

MODEL	4.5A	5A	5.6A
Power	4 kW	7.5kW	11 kW
Voltage	415V / 50Hz / 3PH		
Speed	2900 rpm		
Pressure	4603 - 4447 Pa	5697 - 5323 Pa	7182 - 7236 Pa
Air Flow	1174 - 2062 m <sup>3</sup> /h	1610 - 3166 m <sup>3</sup> /h	2262 - 3167 m <sup>3</sup> /h
Size	657 x 495 x 778mm	730 x 580 x 892 mm	817x 690x 958mm
Net Weight	45kg	51 kg	71 kg
Stock Code	881102010	881102021	881102029

\*\*\* Product's specification subject to change without further notice.  
\*\*\* Actual product may slightly differ from pictures shown.